

REV.	LOCAS.	DESCRIPTION	DATE	DRAWN
01		轉量產版	2010.11.8	zhou
02	△	變更標識部份尺寸	2010.11.8	wu
03	△	變更料號	2010.11.8	wu

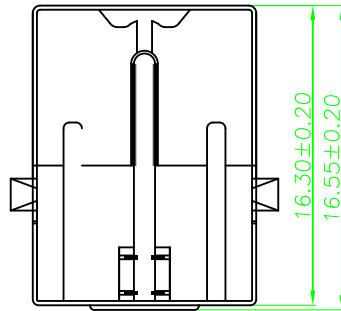
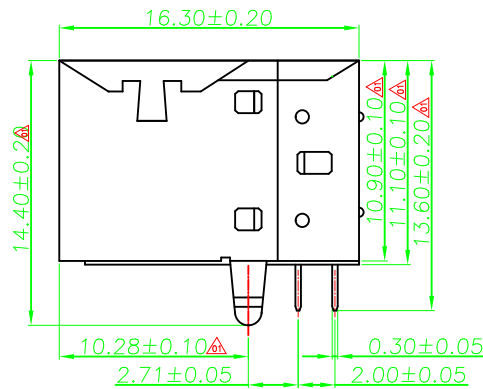
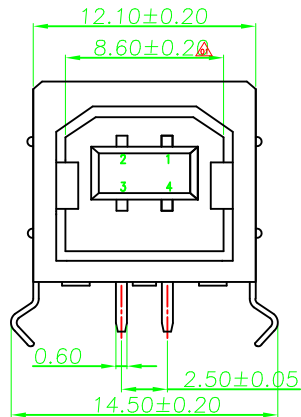

Electrical Characteristics:
 Contact Current Rating: 1AMPERES.
 Dielectric Withstanding Voltage: AC 500V R.M.S
 Insulation Resistance: 500 Megohms minimum AT DC 500V
 Contact Resistance: 30 Milliohm Maximum.
 Operating Temperature: -55℃ TO +105℃

Mechanical characteristics:
 Contact Insertion Force: 4.0KG Maximum
 Contact separation force: 2.0KG minmum.

Materials:
 Contact: Bronze
 Insulator: P.B.T UL94V-0 RATED
 Shell : Cold rolled steel

Finishes:
 Contacts: Gold flashed 1U",3U",5U",10U" 15U",30U"
 Shell: Nickel, Tin or Gold Plated
 All materials must be Geron materials

Ordering Information

GREU102-004 XX X XX - 4 △

No. of Pins per Row: 004
 Contact plating:
 01-Tin
 02-Gold Flash
 05-Gold/Tin(Standard)
 55-15U" Gold/ Tin
 58-30U" Gold/Tin
 ...
 Plastic Color:
 A= Black
 D= White
 ...
 SHELL PLATING:
 01-Tin
 02-Gold Flash
 04-Nickel
 ...

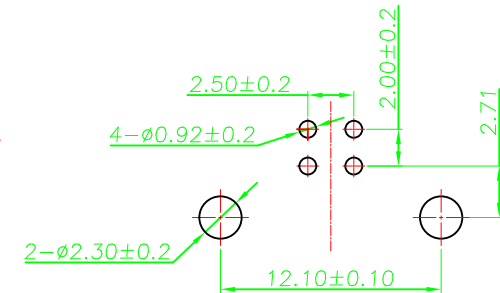

Recommnd PCB Layout

GERON ELECTRONIC CO.,LTD

GENERAL TOLERANCE

X.* ± 1.5°	X. ± 0.30
.X* ± 1.0°	.X ± 0.20
.XX* ± 0.5°	.XX ± 0.15
.XXX* ± 0.3°	.XXX ± 0.10

DESIGN:

DATE: 2010.11.8

DWG. NO.

GREU102-004 △ 4

TITLE:

USB B TYPE SOCKET
90° DIP

CHECKED:

DATE:

PART NO.

GREU102-XX-X-XX--4 △

AUDITED:

DATE:

REV.	UNIT.	SCALE.	PAGE.
03	mm	1:1	1/1