

特性: Specifications:

- 電器: Electrical:
 - 接觸阻抗: Contact Resistance: 30 milliohms MAX.
 - 耐電壓: Dielectric Withstanding Voltage: 500 V AC. AT Sea Level.
 - 絕緣阻抗: Insulation Resistance: 1000 MEGA ohms MIN.
 - 機構: Mechanical:
 - 結合力: Mating Force: 4.0 KG MAX. 最大4kg.
 - 拔出力: Unmating Force: 0.7 KG MIN. 最少0.7kg.
 - 材料: Material:
 - 塑膠: Housing: High Temperature Thermoplastics, UL 94V-0 耐高溫塑膠.
 - 端子: Contact: Copper Alloy. 銅合金.
 - 鐵殼: Shell: Copper Alloy. 銅合金.
 - 電鍍: Finish:
 - 端子: Contact: Plated Gold in Mating Area; Tin On Solder Tails. 接觸點鍍金. 腳鍍錫
 - 鐵殼: Shell: Tin Plating. 鍍錫
- All materials must be Geron materials

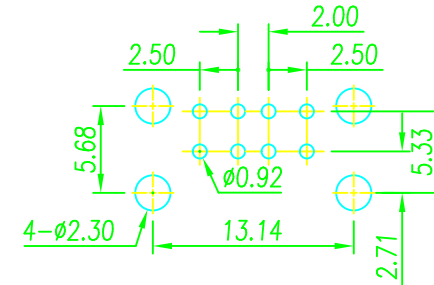
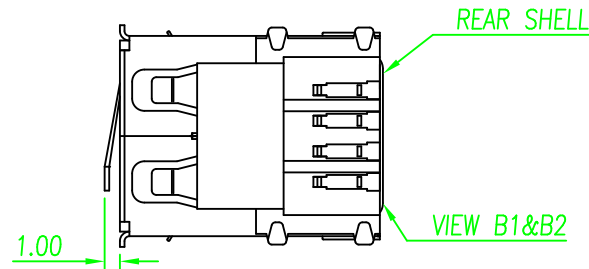
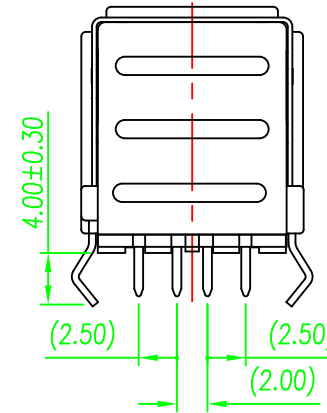
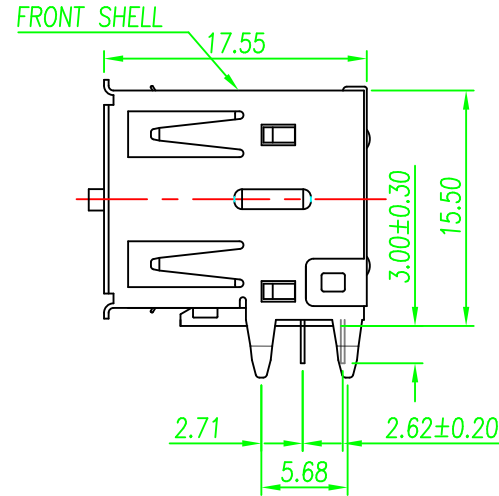
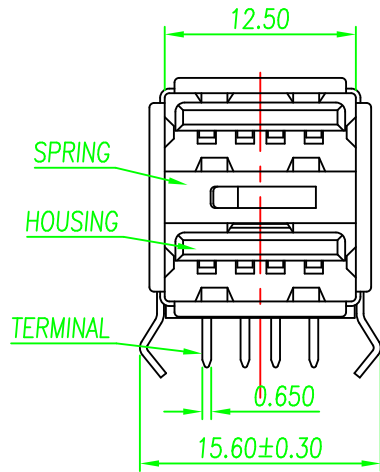

PC BOARD LAYOUT

Ordering Information

GRE103 - 8 X X X

Contact plating	Plastic Color
01-Tin	A= Black
02-Gold Flash	D= White
05-Gold /TIN	
55-150" Gold/ Tin	
58-300" Gold/Tin (Standard)	

Geron Electronic Co.,Ltd

REV.	UNIT	SCALE
01	mm	F



GENERAL TOLERANCE	
X.*(REF)±5°	X. ±
.X* ± 2°	.X ± 0.38
.XX* ± 1°	.XX ± 0.25
.XXX*± 0.5°	.XXX ± 0.13

DRAWN ZHANG
CHECK
APPROVE

DATE 09-16-04'
DATE
DATE

DWG. NO. GRE103
PART NO. GRE103-8 XX X

TITLE
USB A TYPE 90°
????